

Phone Stand Overview

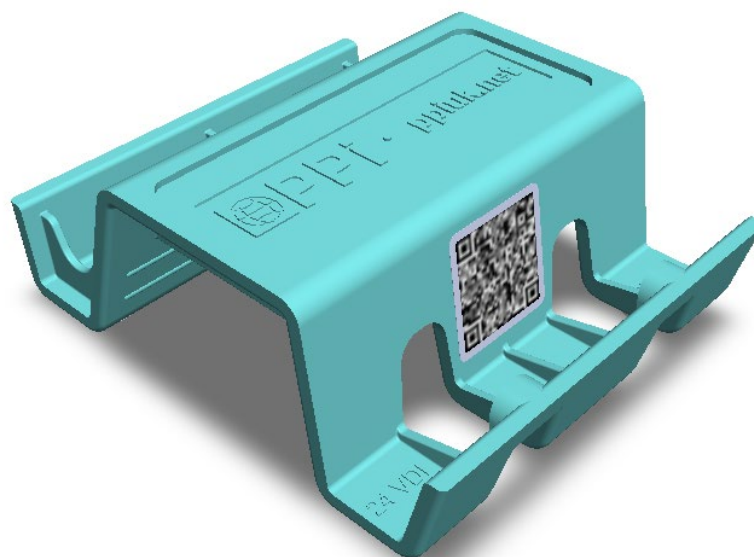

www.ppiuk.net info@ppiuk.net
T 01279 445041 F 0870 460 1540
Capital Place, Lovet Road, Harlow
Essex CM19 5AS
Directors: K Smith F L Smith
Registered in England No. 2188508

Features

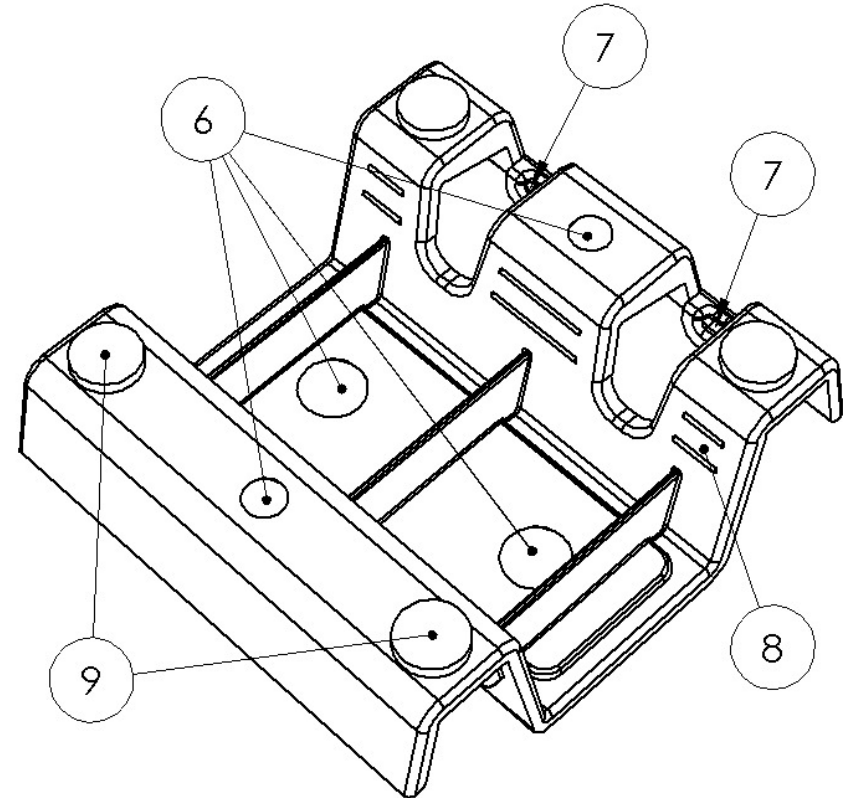
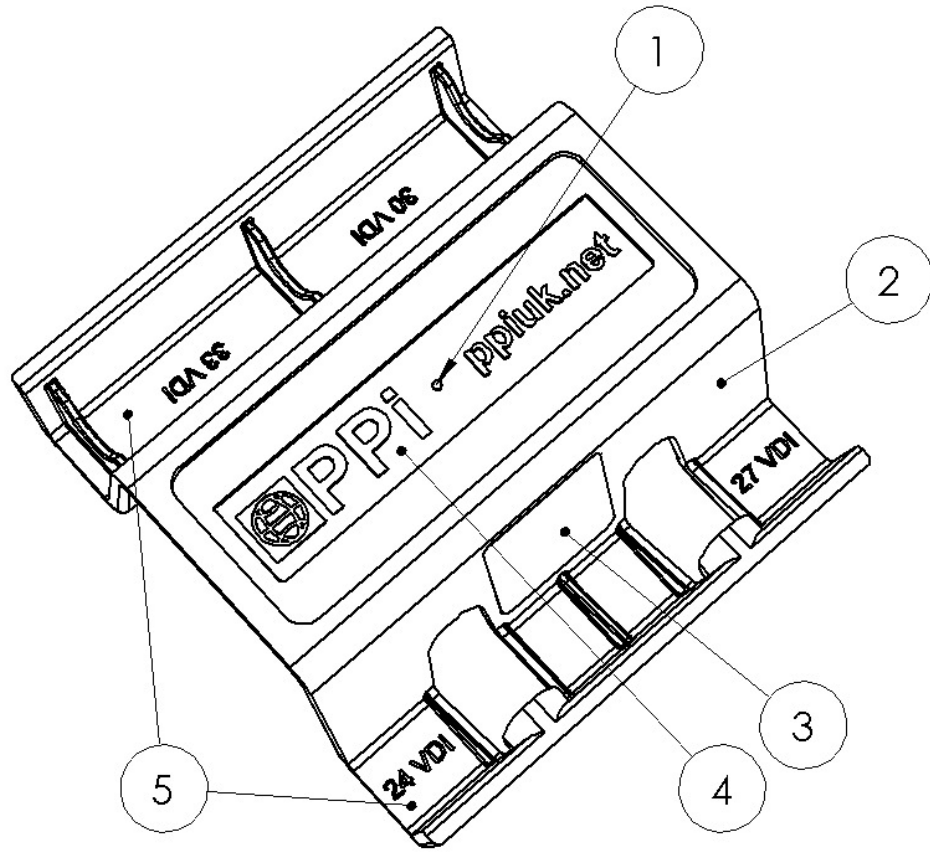

Description

Item No.	Description
1	Hot runner: A hot runner mould tool is one in which the runner remains at melt temperature. Only the mouldings are produced thus saving runner wastage.
2	Commercial polish.
3	Second Ops: Label, applied by hand with alignment jig.
4	Interchangeable logo insert.
5	VDI guide, 24, 27, 30 & 33.
6	Ejector: A device for forcing the moulding components out of the mould tool after the mouldings have solidified and the mould opens. These are available as pins and blades or may be specially shaped.
7	Coring: To keep wall thickness consistent minimise post-mould shrinkage.
8	Snatch: Features designed to ensure that the part is held on the correct half of the tool so that they may be successfully ejected.
9	Second Ops: Foam pads (x4), applied by hand with alignment jig.

Brief Overview

We are an ISO 9001 and IATF 16949 injection moulding and toolmaking company with full design and DFM capabilities that can offer full inspection and validation of parts through to PPAP.

We can work from a sketch or model or reverse engineer by laser scanning - creating CAD models then performing DFM followed by in house tooling and production thus making it a seamless process from part concept to production.

We also have a modular tooling system that allows us to make cost effective tooling inserts that in turn can produce very small runs to millions of parts at minimal costs.

We have immediate capacity in machines ranging from 22T through to 300T at our Harlow premises mainly automated and can also offer assembly and packing options if required.

The key contacts for you are:

Keith Smith – keith@ppiuk.net - 07970 47 63 43 - Managing Director

Andy Bremner – andy@ppiuk.net - 07789 86 57 54 - Operations Manager

Kristof Molnar – kristof@ppiuk.net - 01279 44 50 41 - Quality Manager

Paul Marshall – paul@ppiuk.net - 07769 96 15 78 - Project Manager

Or visit www.ppiuk.net

Brief Overview

Points of interest include:

- VW Group Approved.
- Bentley Motors A Grade Supplier.
- Smithkline Glaxo Approved Supplier.
- Aston Martin Approved Supplier.
- Microsoft Approved.
- G4S Security Approved.
- ISO9001.
- IATF 16949.
- In House Technical Centre.
- In House Tool Design.
- In House State of the Art Toolroom.
- In House Moldex3D Moldflow Analysis – complimentary with ordered projects.
- High precision Laser Scanning:
LC15Dx | CMM scanning | Nikon Metrology
- 3D Colour mapping.
- Reverse Engineering.
- SolidWorks.
- AutoCAD LT.
- Fusion 360.
- Creo (Formerly Pro Engineer).
- Visi.
- Spaceclaim.
- Mouldshop with Eleven Machines.
- Project Management.
- Clean room to Class 7.
- Extensive experience in the provision of high-end interior 'A' surface and exterior automotive mouldings and assemblies.
- Air-conditioned rooms with high-speed WI-FI and LAN dedicated for customer use whilst on site.
- Electric car charge points for customers and staff.